

\$ Butterfly

Copyright 1998-99 Stephen Hecht. All Rights Reserved

A dollar bill makes a model 55mm long with a 65mm wingspan. For your first attempt, begin with a 3x7 rectangle larger than a dollar bill.

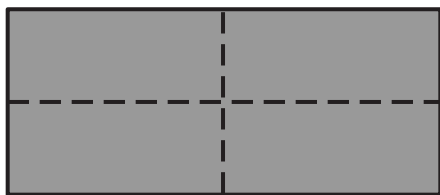

1. Begin black side up. Valley-crease, the horizontal not too sharply. Turn over.

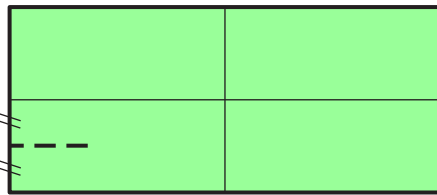

2. Crease halfway, making a mark.

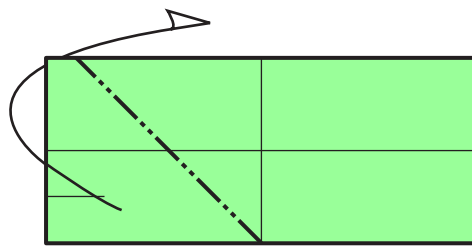

3. Soft mountain-fold on 45-degree line.

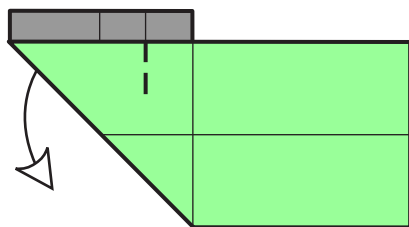

4. Pinch where mark from step 2 hits edge. Unfold.

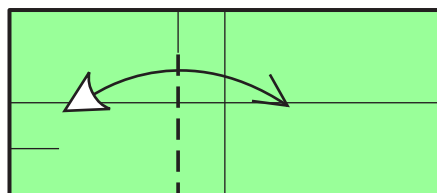

5. Use mark from previous step to make this valley-fold. Unfold.

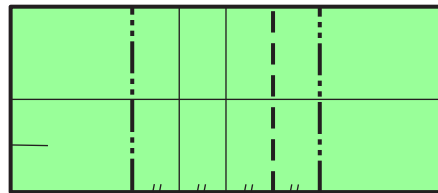

6. Use the 2 existing creases to add 3 more.

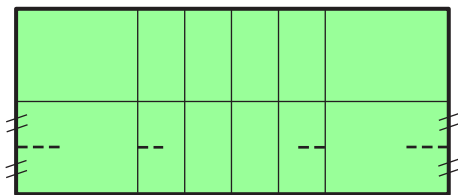

7. Pinch halfway marks where indicated.

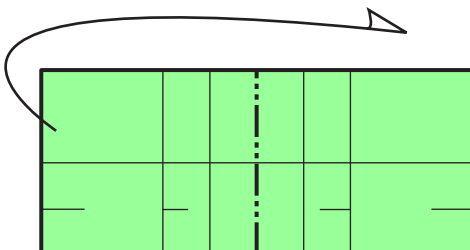

8. Mountain in half.

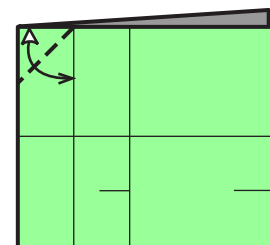

9. Crease and unfold.

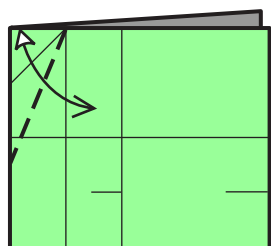

10. Crease and unfold, bisecting. Crease from previous step will align with vertical crease.

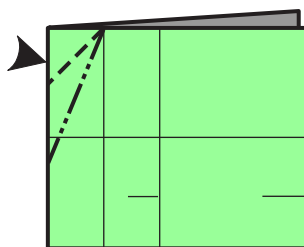

11. Reverse-fold, in-and-out.

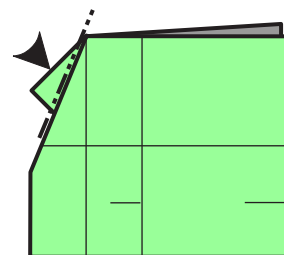

12. Reverse-fold.

\$ Butterfly (continued)

Copyright 1998-99 Stephen Hecht. All Rights Reserved

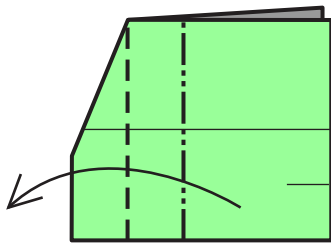

13. Pleat top layer on existing creases.

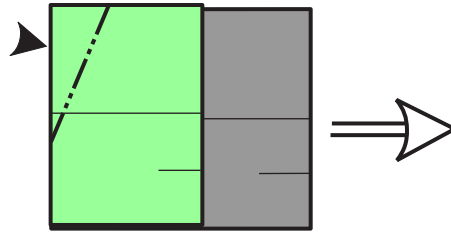

14. Reverse-fold, following the hidden edge. Unfold to step 13.

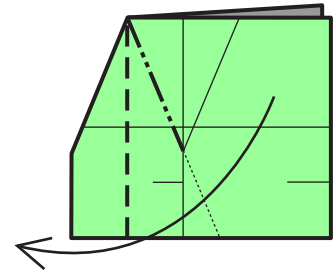

15. Pleat top layer, softly on the dotted line.

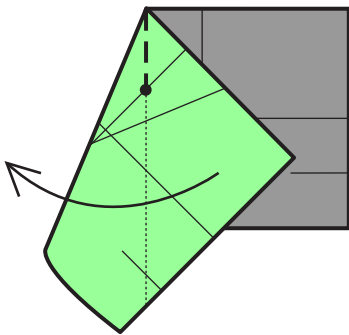

16. Follow hidden vertical edge. Softly on dotted line.

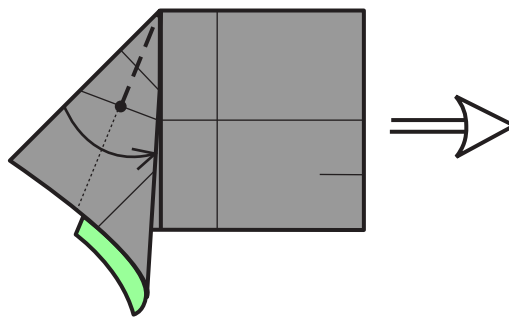

17. Bisect angle. Softly on dotted line. Unfold to step 13.

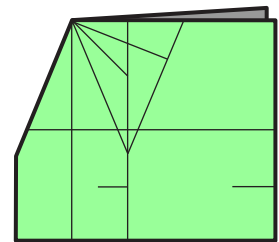

18. Creases exist as shown.

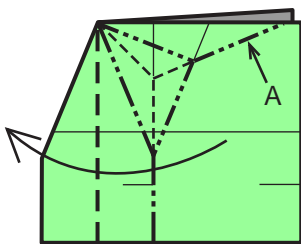

19. Collapse on the creases. First close up the mountain-fold triangle, pinching the tiny new valley-fold. Then flatten to form mountain-fold "A".

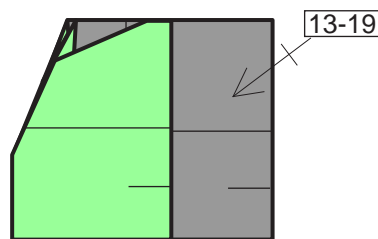

20. Note that "A" does not reach corner. Repeat 13-19 on rear flap.

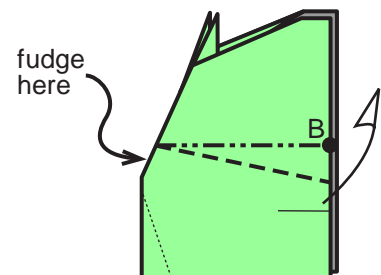

21. Pleat. Mountain-fold is the existing half-line. For the valley, bring the 1/4-mark to lie under "B". The dotted line is a hidden mountain-fold caused by shifting paper.

\$ Butterfly (continued)

Copyright 1998-99 Stephen Hecht. All Rights Reserved

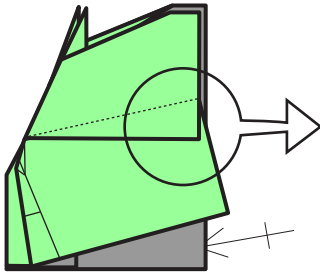

22. Note shifted creases in fudged area. It needn't be precise, it will be hidden later. Repeat 21 behind.

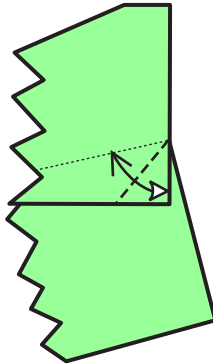

23. Close-up of right edge. Fold and unfold to hidden edge (hold model up to the light).

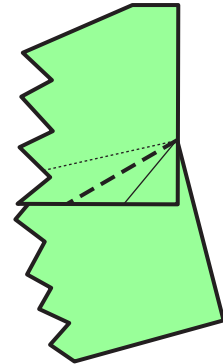

24. Fold and unfold (bisection), aligning previous crease with hidden edge.

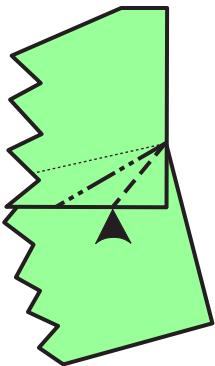

25. Reverse-fold, in-and-out.

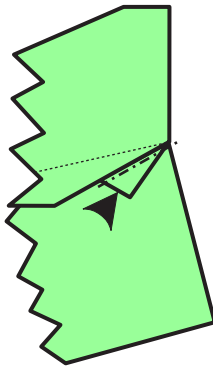

26. Reverse-fold. These steps are similar to 9-12. Turn over.

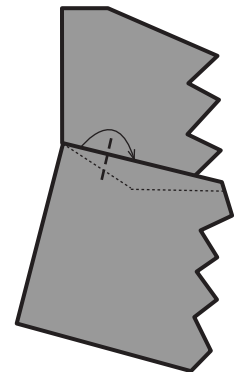

27. Fold and pinch, where limited by most recent reverse-fold.

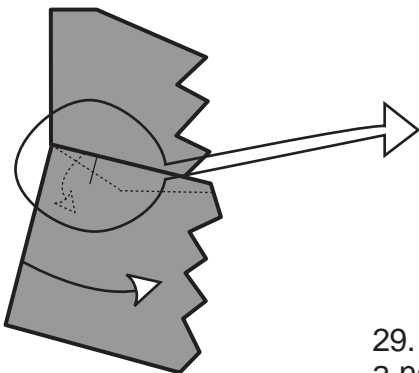

28. Undo the reverse-fold from step 26. Then spread the area towards the right.

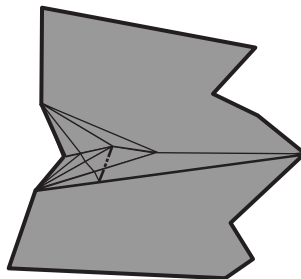

29. Push from behind and create a new mountain-crease linking the base of the reverse-folds to the pinch mark of step 27.

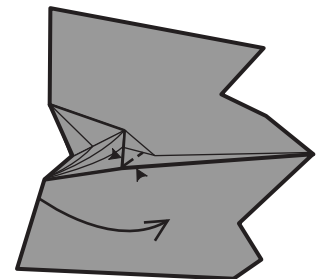

30. Begin to flatten by pinching where shown. Swing the standing edge to the right.

\$ Butterfly (continued)

Copyright 1998-99 Stephen Hecht. All Rights Reserved

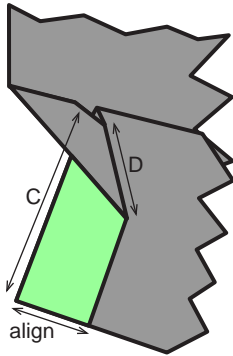

31. To flatten, first align bottom edges. Then flatten "C", then flatten "D". Careful of tearing due to imprecision.

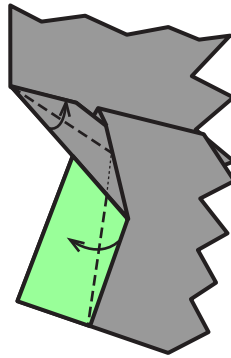

32. Swivel. The upper crease partially exists. Use it to start the swivel and locate the end of the vertical crease.

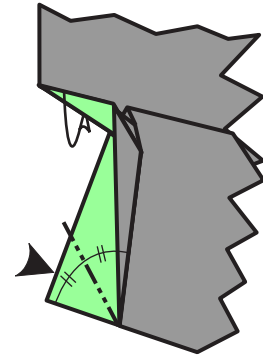

33. Wrap top layer around to the inside. Reverse-fold corner, noting the bisected angle.

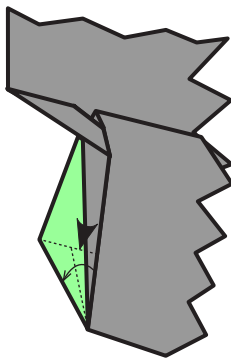

34. Reverse-fold hidden corner, bisecting. Then unfold it.

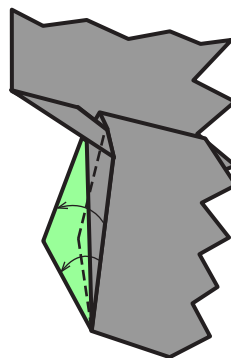

35. Crease and unfold. Lower crease bisects. Upper crease aligns vertical edges.

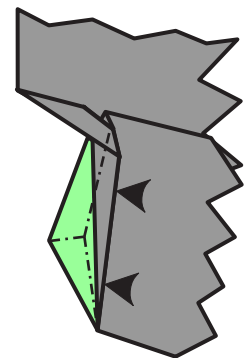

36. Reverse the two creases just made and add the tiny mountain-fold, pushing edge towards the left (model not flat).

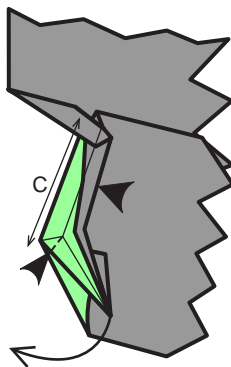

37. Still pushing towards the left, also push in at the tiny valley-fold, swinging the point down to align with edge "C".

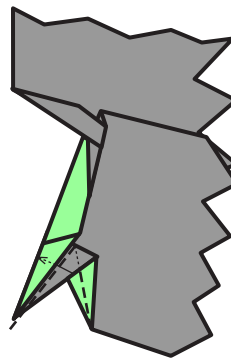

38. Model is flat again. Swivel on existing creases and tuck between layers.

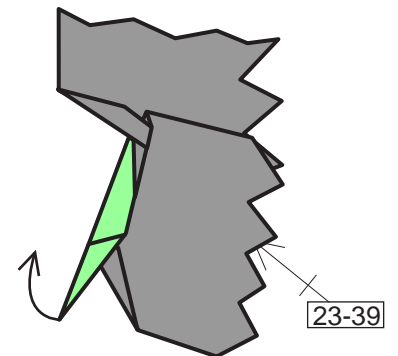

39. Curve the tip towards you a bit. Helps keep together. Repeat steps 23-39 on the other wing.

\$ Butterfly (continued)

Copyright 1998-99 Stephen Hecht. All Rights Reserved

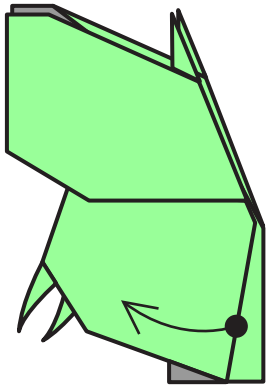

40. Entire model again. Spread upper layers a bit.

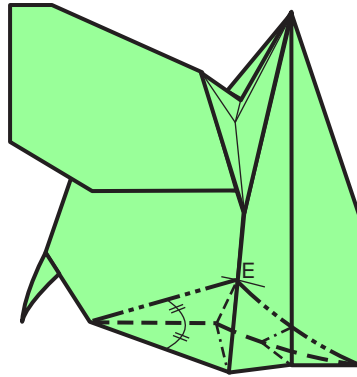

41. "E" is the mark made in step 7. First make the long mountain-folds. Then make the left valley (an exact bisection). Then make the right valley (not an exact bisection), closing up the model.

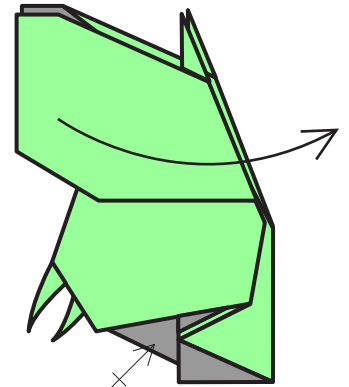

42. Thus. Repeat 40-41 on other side. Then open model out.

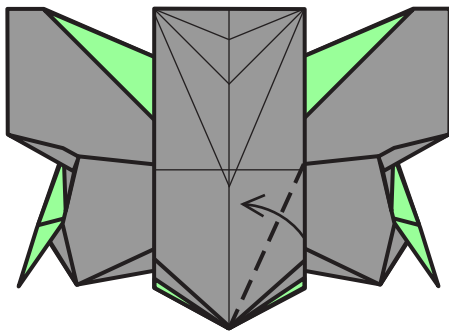

43. Valley-fold, limited by the folds of step 41. If you have been accurate, it will hit the bottom corner. Unfold.

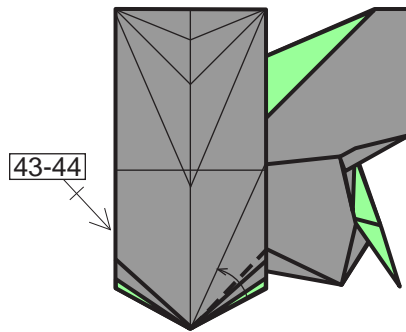

44. Valley to previous crease and unfold. Repeat 43-44 on the left. Close up the model again.

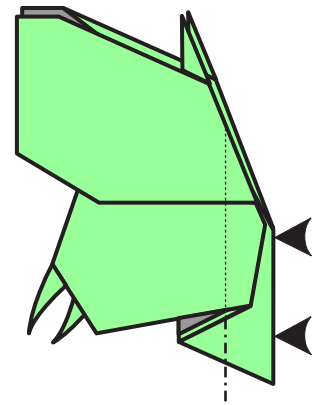

45. Closed-sink central ridge halfway.

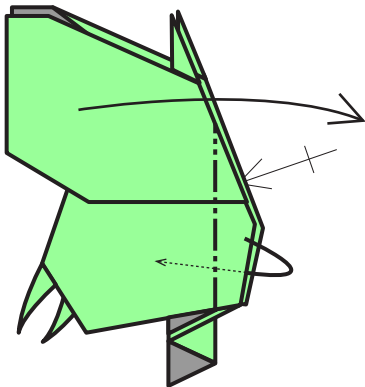

46. Tuck into sink, creasing sharply. Repeat behind. Then open model again.

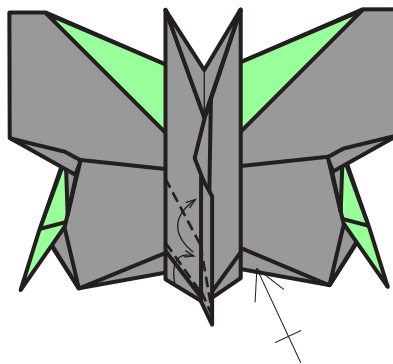

47. Reform valley-folds from 44, then valley folds from 43. Close up model, adding new mountain folds.

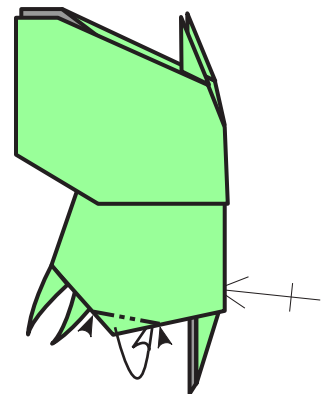

48. Mountain to shape wing. Reverse-fold at overlaps to help secure. Repeat behind. Bottom half is now done.

\$ Butterfly (continued)

Copyright 1998-99 Stephen Hecht. All Rights Reserved

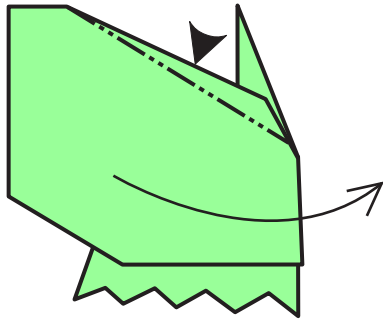

49. Top of model. Closed sink (limited by paper at right). Then lift wing.

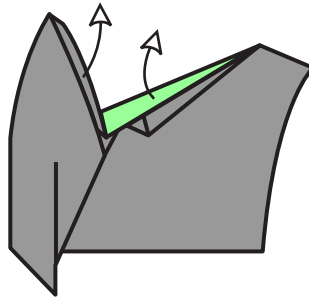

50. Lift the single-ply "reverse-fold", exposing the underside of the sink.

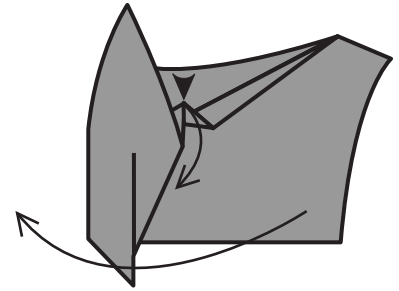

51. Reverse-fold the small corner, and close up the model. This distributes the layers of the sink more evenly.

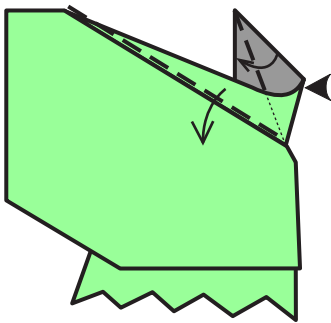

52. Squash the flap lifted in step 50, on existing creases.

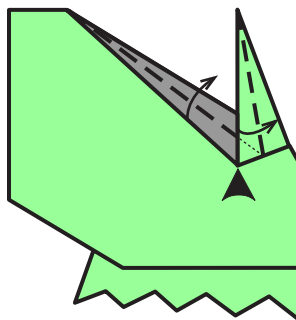

53. Squash again.

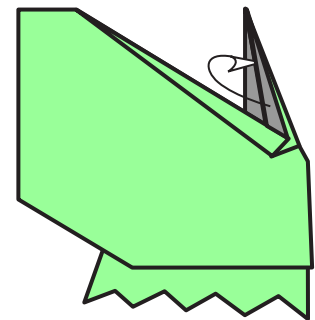

54. Wrap raw edge to the inside.

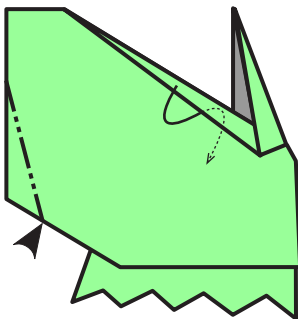

55. Tuck long flap into sunken pocket. Mountain-fold to shape wing. Reverse-fold at overlap to help secure.

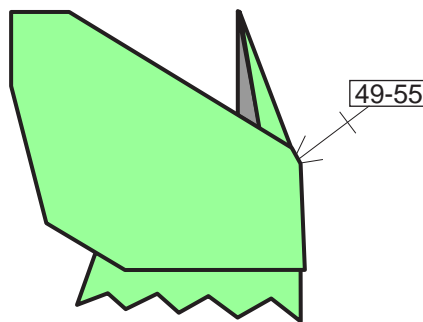

56. Like so. Repeat 49-55 on other wing.

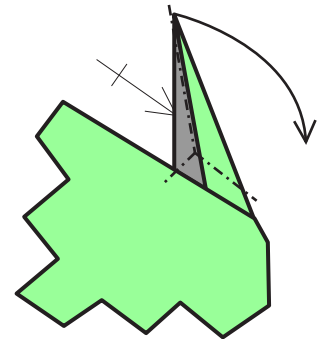

57. Double-rabbit-ear the point to form antenna. Repeat behind. Distribute layers evenly.

\$ Butterfly (continued)

Copyright 1998-99 Stephen Hecht. All Rights Reserved

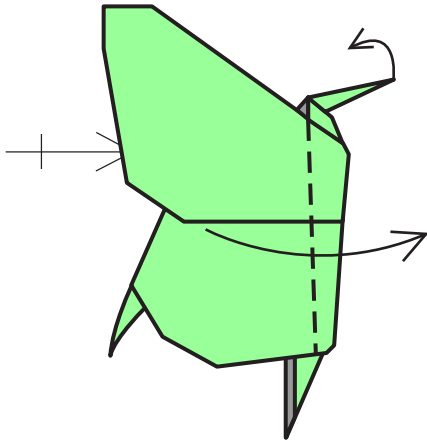

58. Curl antenna. Fold wings, not too sharply, where limited by body. Repeat behind.

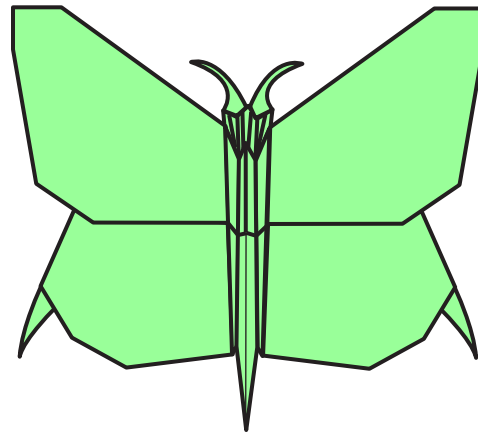

59. Finished.