

Biplane II

by Marc Kirschenbaum (NY)

©1996

Complex

A 10" square makes a model with a 4" wingspan

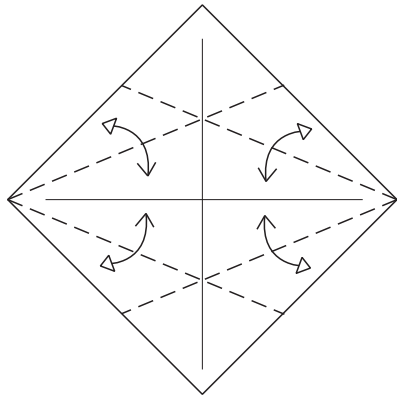

1. This will be the color of the body. Precrease along angle bisectors.

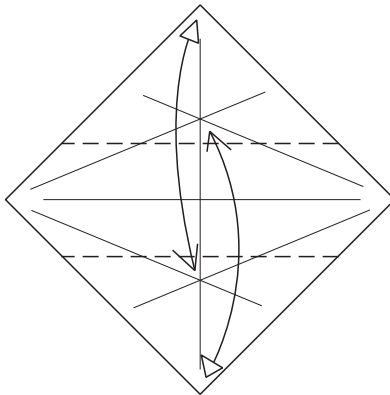

2. Valley the corners to the intersections of creases and unfold.

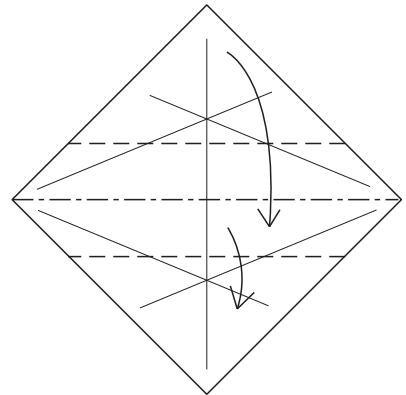

3. Pleat along existing creases.

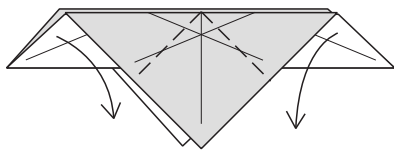

4. Valley to center.

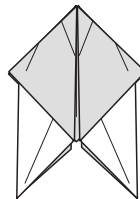

5. Turn over.

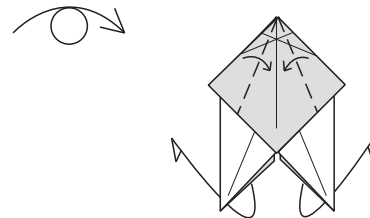

6. Fold sides to center, allowing flaps to swing outwards.

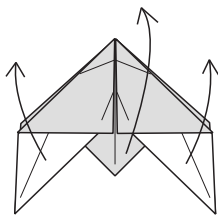

7. Unfold entirely.

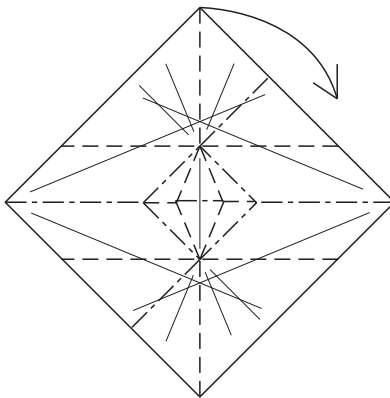

8. Collapse.

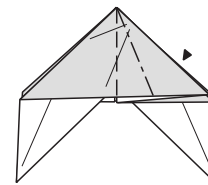

9. Squash the center flap.

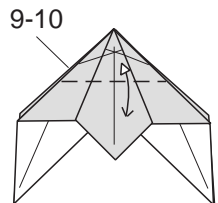

10. Valley down as far as possible and unfold. Repeat steps 9-10 behind.

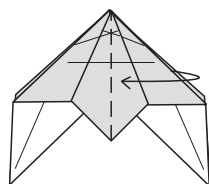

11. Spread open to reveal small flap.

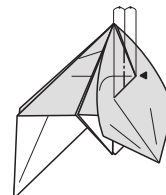

12. Sink triangularly halfway.

12-13

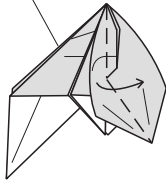

13. Close back up. Repeat steps 12-13 on the other side.

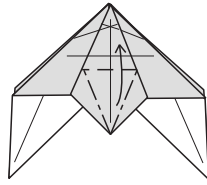

14. Petal fold.

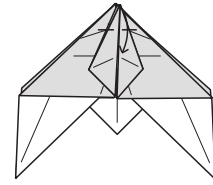

15. Valley to intersection of creases.

14-16

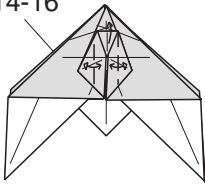

16. Precrease sides of flap and then open up. Repeat steps 14-16 behind.

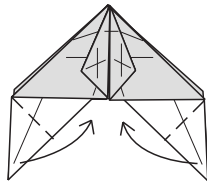

17. Valley corners. Turn over.

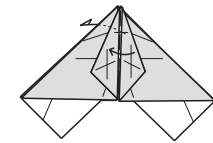

18. Swing a flap over, front and back.

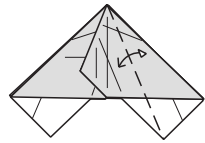

19. Precrease through all layers.

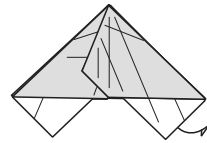

20. Unfold bottom flap.

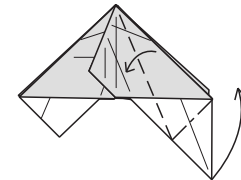

21. Squash. Do not flatten completely.

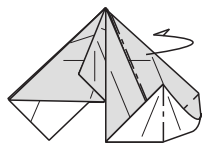

22. Wrap around to make symmetrical.

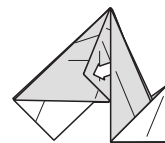

23. Pull out single layer.

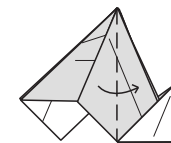

24. Valley over.

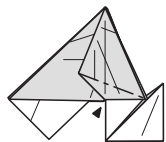

25. Reverse fold.

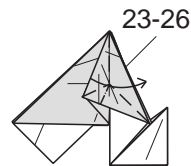

26. Swing over flap while incorporating a reverse fold. Repeat steps 23-26 behind.

18-26

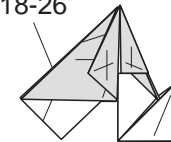

27. Repeat steps 18-26 in mirror image.

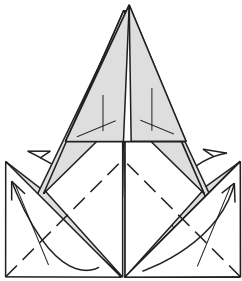

28. Valley up corners.

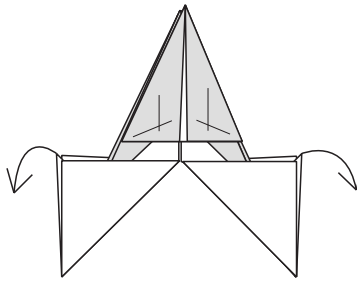

29. Pull out hidden corners.

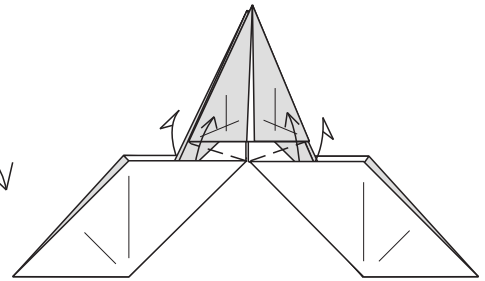

30. Pull out hidden points.

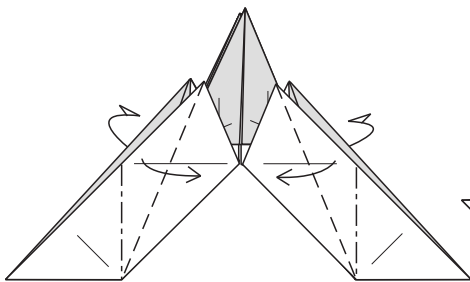

31. Crimp sides.

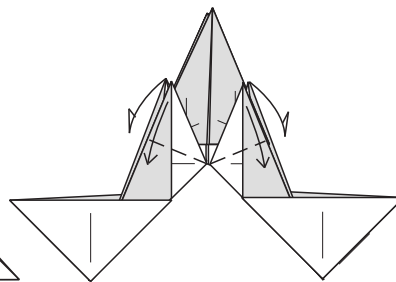

32. Valley down four points.

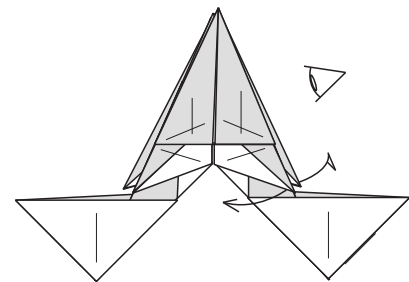

33. Stretch apart sides.

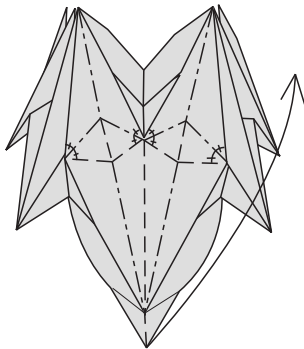

34. View from step 33. Double-crimp upwards and flatten.

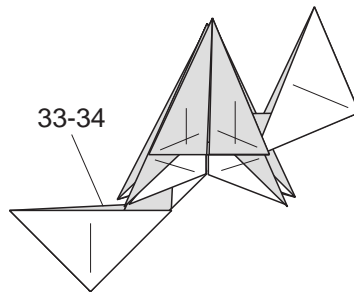

35. Repeat steps 33-34 on other side.

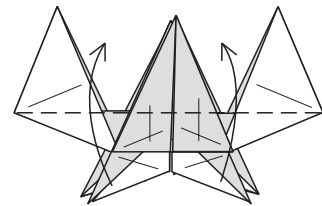

36. Lightly swing up top section.

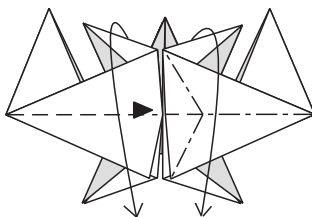

37. Swing back down while collapsing the top single layer outwards.

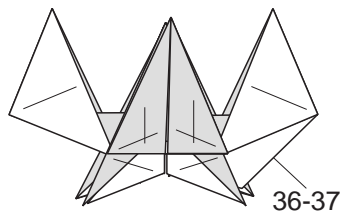

38. Repeat steps 36-37 behind.

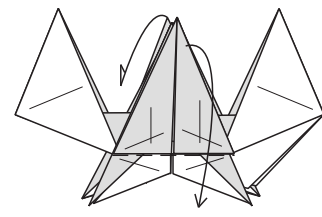

39. Swing down flaps.

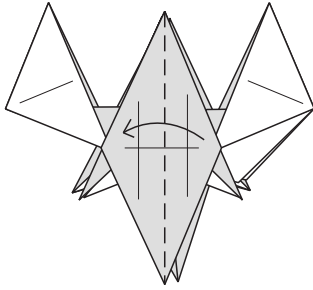

40. Swing over a layer, undoing reverse fold. Repeat behind.

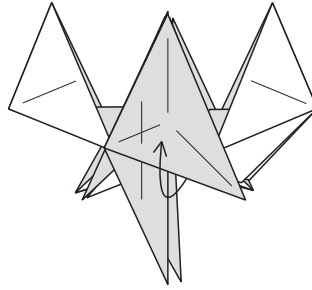

41. Wrap around a single layer. Repeat behind.

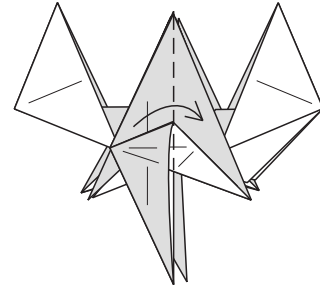

42. Swing back. Repeat behind.

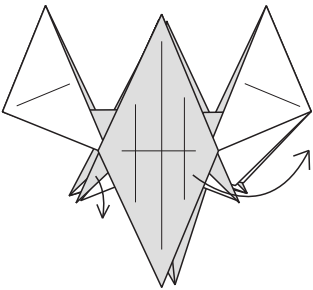

43. Pull flap out, releasing layers at left. Repeat behind.

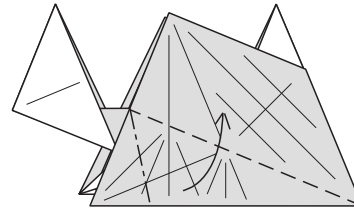

44. Asymmetrical squash. Repeat behind.

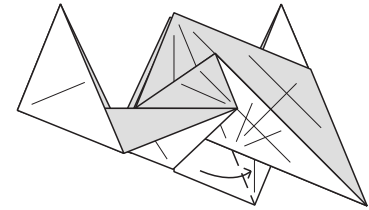

45. Valley layer through. Repeat behind.

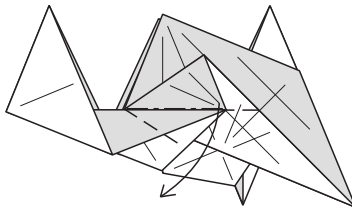

46. Swivel down. Repeat behind.

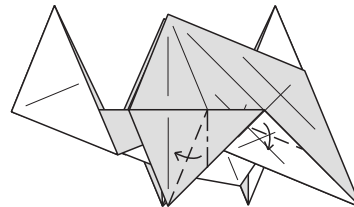

47. Swivel over. Repeat behind.

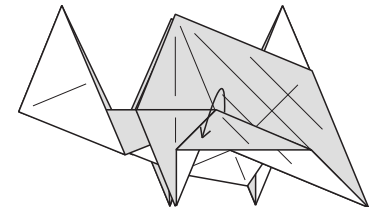

48. Bring single layer to surface (closed sink). Repeat behind.

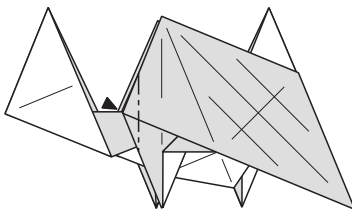

49. Sink triangularly, so as to match up with the folded edge in the middle. Repeat behind.

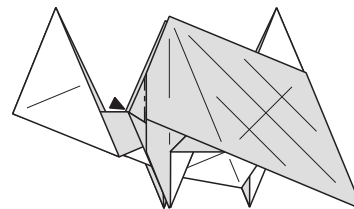

50. Sink triangularly again. Repeat behind.

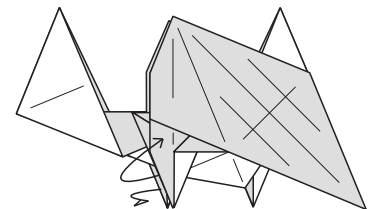

51. Wrap around a single layer. Repeat behind.

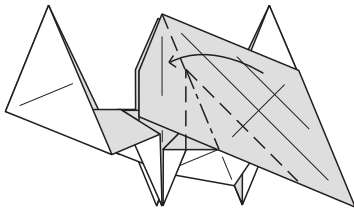

52. Swing flap over while incorporating a reverse fold along existing creases.

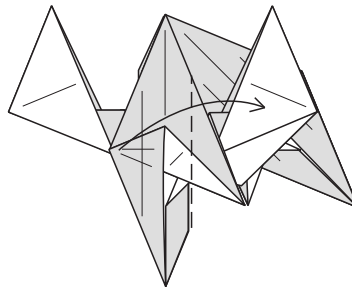

53. Swing over two layers. Model will not lie flat.

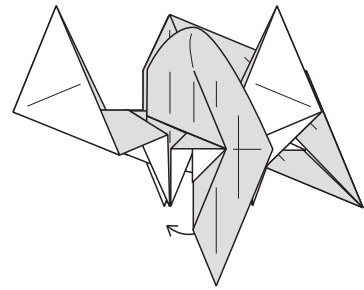

54. Pull out single layer from behind.

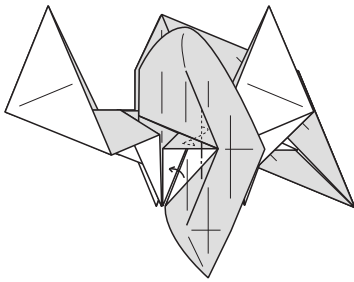

55. Swivel under.

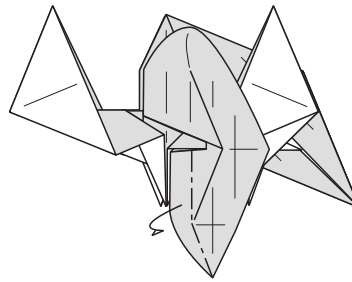

56. Swing single layer back.

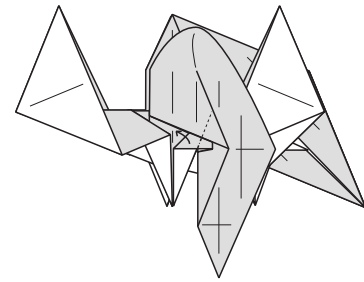

57. Swivel up.

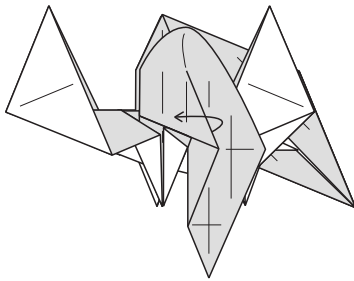

58. Wrap single layer around (closed sink).

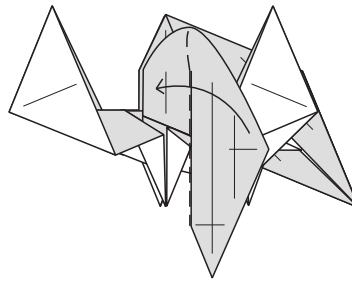

59. Close model back up.

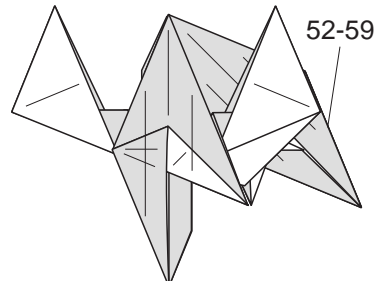

60. Repeat steps 52-59 behind.

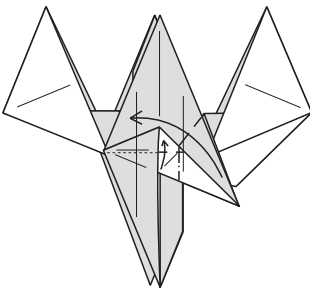

61. Swing over flap while pulling up a layer through the pocket. Repeat behind

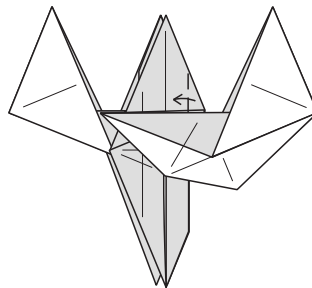

62. Valley along existing crease. Repeat behind.

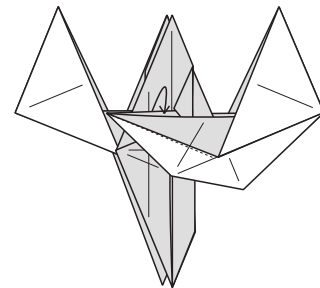

63. Swivel down hidden middle layer into pocket. Repeat behind.

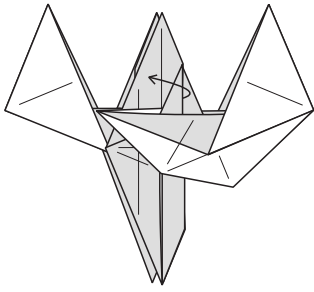

64. Bring single layer to surface (closed sink). Repeat behind.

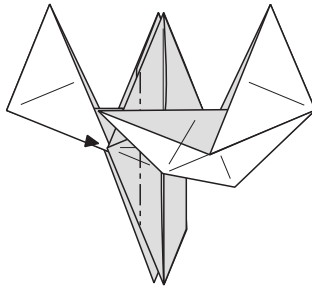

65. Closed sink along existing crease. Repeat behind.

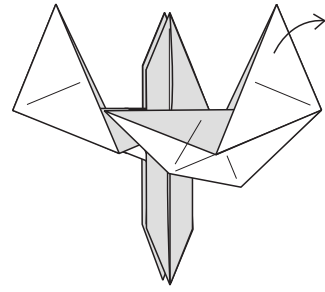

66. Pull point outwards.

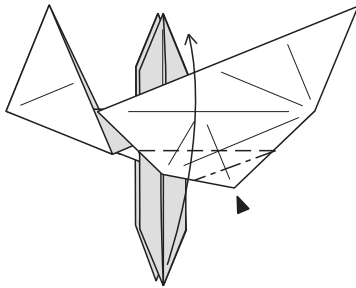

67. Bring the bottom points to the top, allowing the corners to spread sink.

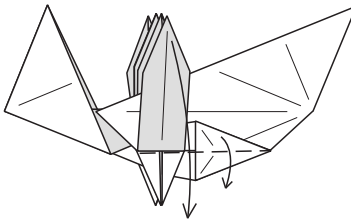

68. Swing down.

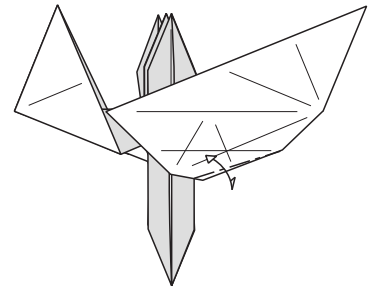

69. Precrease. Repeat with adjacent flap.

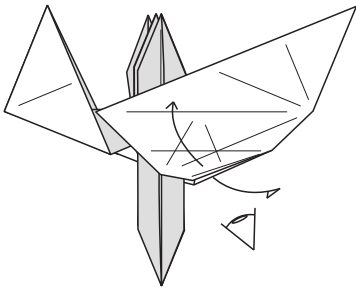

70. Spread apart.

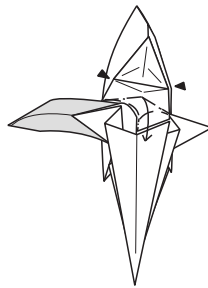

71. View from step 71. Sink single layer through from behind, using the creases from step 69.

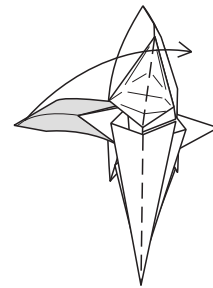

72. The edges of the wing should now be flush. Close the model up.

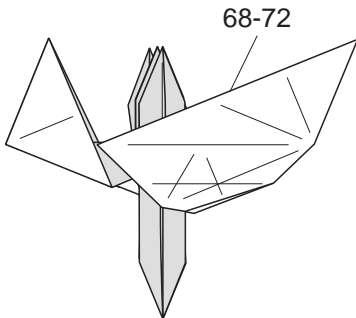

73. Repeat steps 68-72 behind.

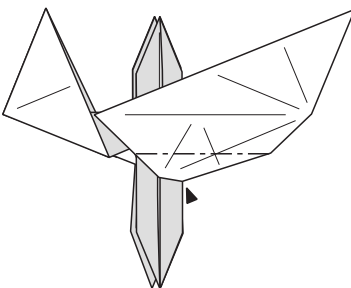

74. Sink triangularly along existing crease. Repeat behind.

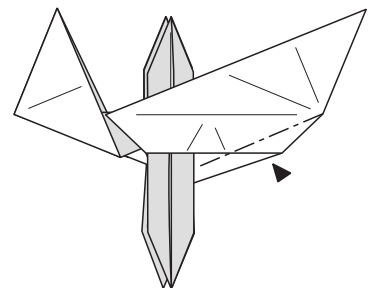

75. Closed sink along existing crease. Repeat behind.

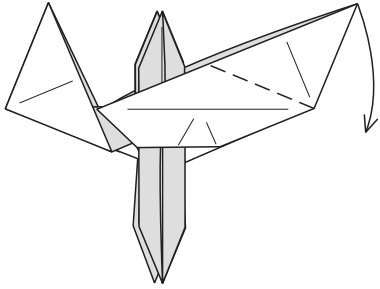

76. Outside reverse fold along existing crease.

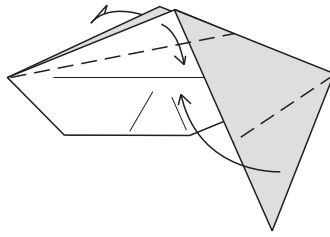

77. Detail of tail. Valley along angle bisectors.

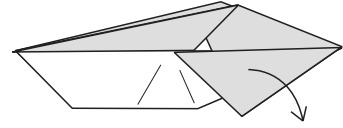

78. Unfold.

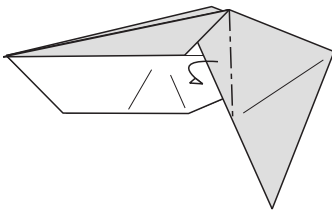

79. Swivel fold. Repeat behind.

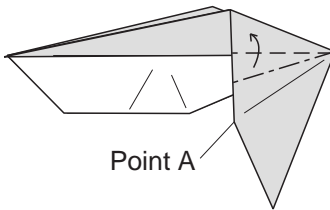

80. Crimp upwards, so point A meets colored raw edge.

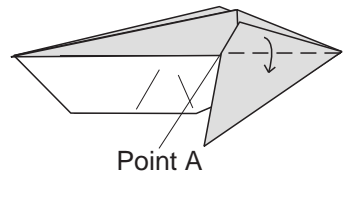

81. Valley down. Repeat behind.

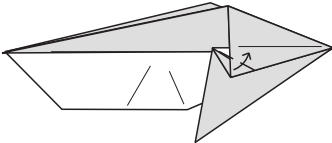

82. Valley along angle bisector. Repeat behind.

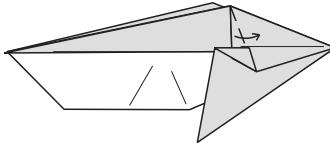

83. Swivel over. Repeat behind.

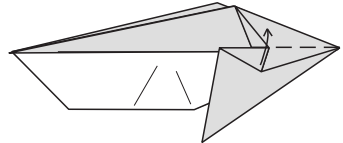

84. Valley up. Repeat behind.

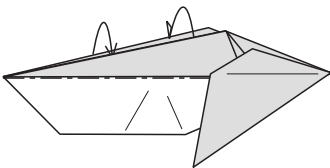

85. Mountain top flaps into pocket.

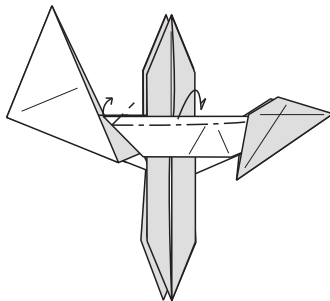

86. Mountain the double layer about 1/4th the width. Towards the tail, the fold will terminate at an angle, and at the other end, a swivel will form. Repeat behind.

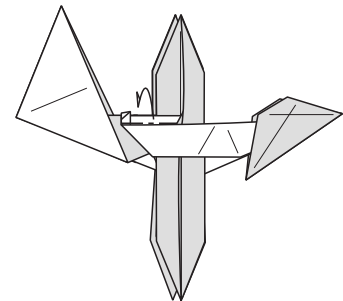

87. Reverse fold back. Repeat behind.

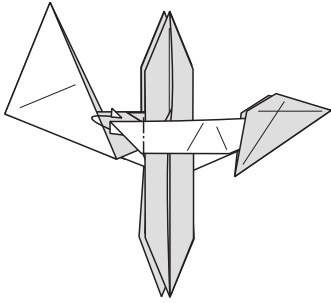

88. Mountain behind wing.
Repeat behind.

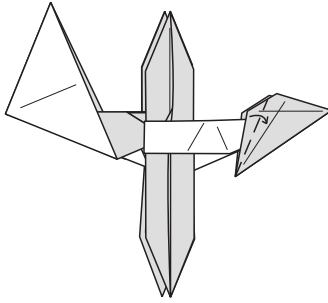

89. Valley to existing crease.
Repeat behind.

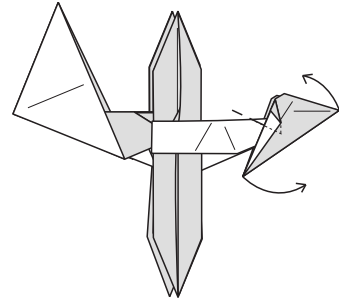

90. Crimp the tail section. See
step 91 for positioning.

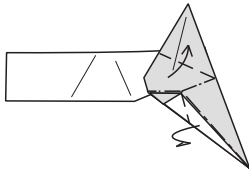

91. Collapse upwards.

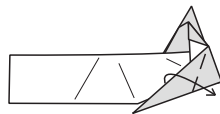

92. Outside reverse fold.

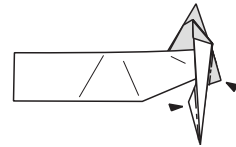

93. Sink the indicated regions.

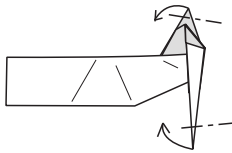

94. Reverse fold the indicated
areas.

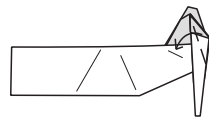

95. Valley over a single layer.
Repeat behind.

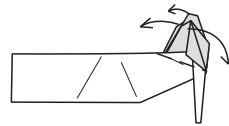

96. Pull the center flap forwards
while pulling the side flaps
outwards.

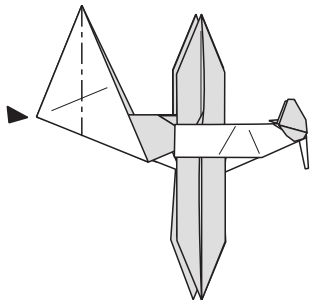

97. Open sink.

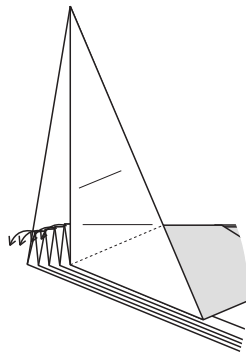

98. Reverse the four hidden
corners down.

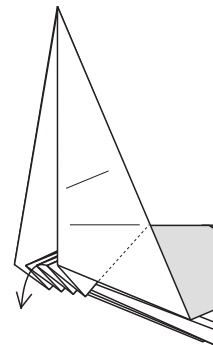

99. Reverse the first of the three
points down. Note how the
bottom five layers are
distributed.

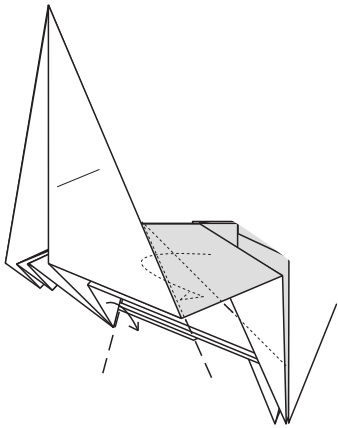

100. Swivel.

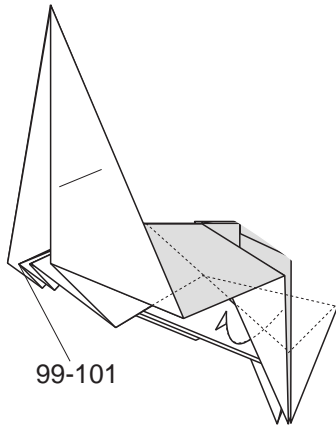

101. Reverse into pocket.
Repeat steps 99-101
behind.

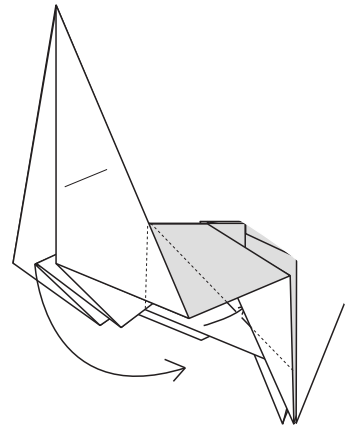

102. Swivel.

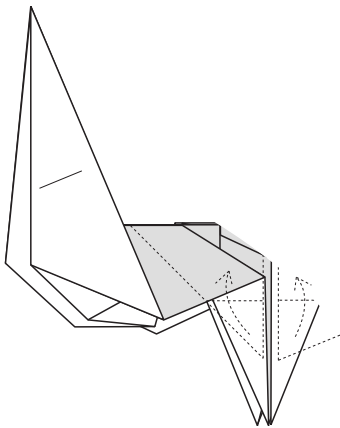

103. Tuck the bottom hidden
points into the center of
the model.

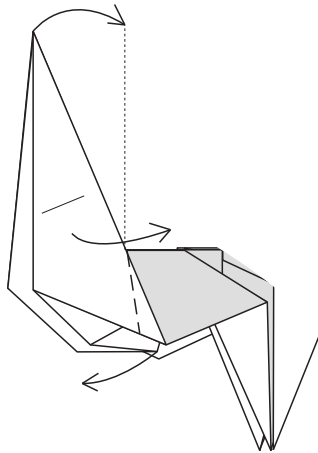

104. Spread apart the flap flat,
while pulling it into an
upright position.

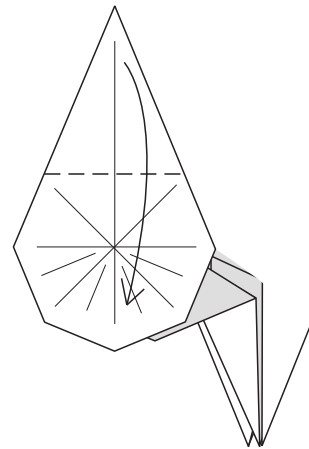

105. Valley down.

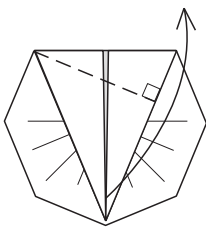

106. Valley up.

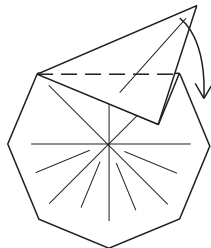

107. Valley down.

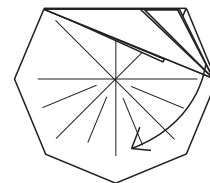

108. Undo pleat.

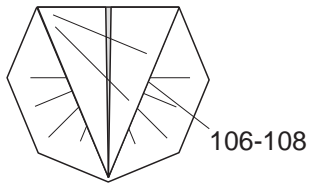

109. Repeat steps 106-108 in mirror image.

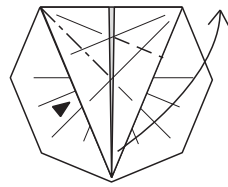

110. Asymmetrical squash.

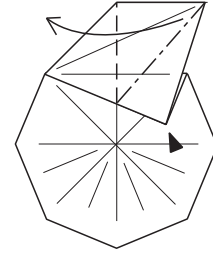

111. Squash.

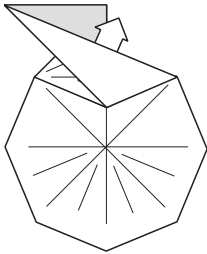

112. Pull out single layer.

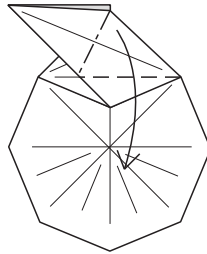

113. Squash.

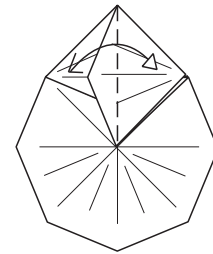

114. Precrease.

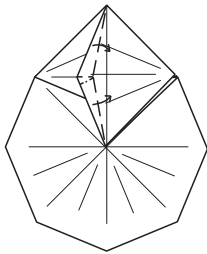

115. Rabbit ear.

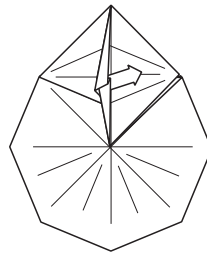

116. Unsink.

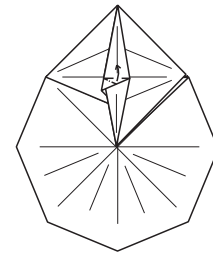

117. Swivel up.

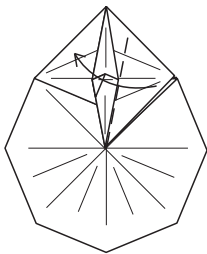

118. Valley over.

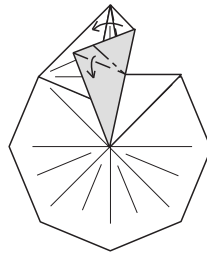

119. Swivel.

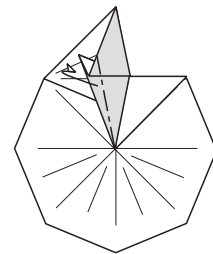

120. Mountain behind.

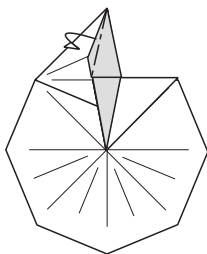

121. Mountain behind.

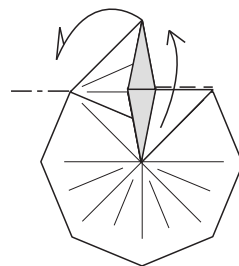

122. Flip the points.

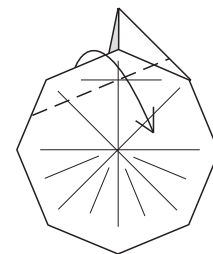

123. Valley through intersection of creases. See step 124 for positioning.

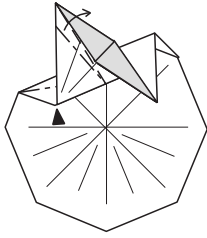

124. Spread squash.

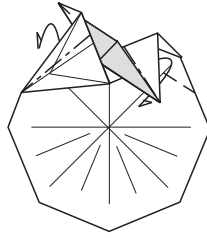

125. Swivel at each side.

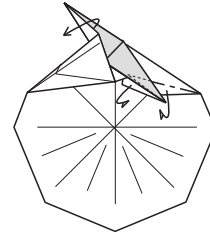

126. Swivel at right. Bring colored layer to surface.

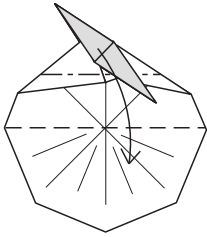

127. Pleat downwards.

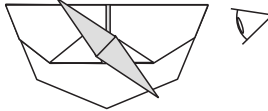

128. Completed propeller.

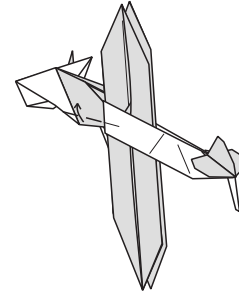

129. Valley up (there are no reference points).

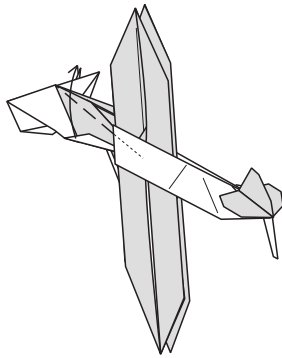

130. Pull the single layer up as far as possible.

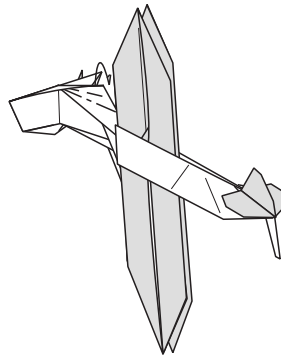

131. Pleat the excess into the center pocket.

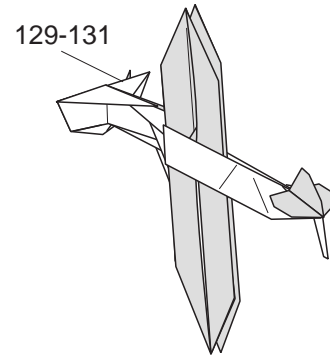

132. Repeat steps 129-131 behind.

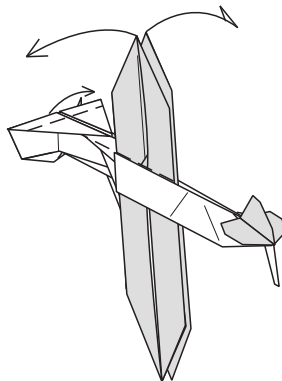

133. Spread the wings apart, allowing the front to spread apart too. To flatten, fold the top of the cowl over.

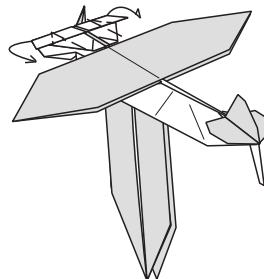

134. Collapse the sides inwards at 90°. You can trim the sides to taste with mountain folds.

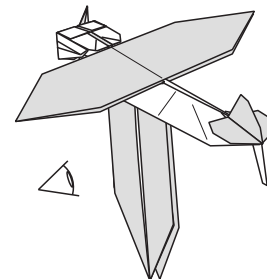

135. Completed cowl.

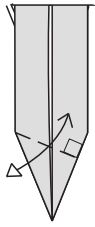

136. View of lower wing. Precrease.

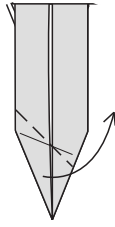

137. Valley at 45° through intersection of precrease and center.

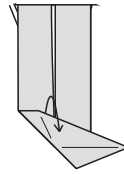

138. Wrap a single layer around.

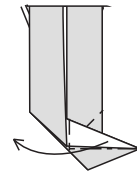

139. Squash over.

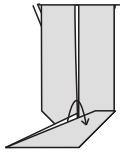

140. Wrap a single layer around.

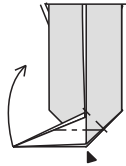

141. Spread squash.

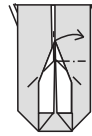

142. Rabbit ear the tip of the strut.

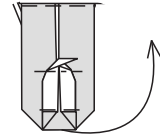

143. Raise the wing and strut, tucking its tip into the pocket on the upper wing. Repeat steps 136-143 on other wing.



144. Detail of landing gear. Precrease.

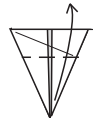

145. Valley up.



146. Pull out a single layer from each side.



147. Valley down while incorporating reverse folds.



148. Shape with mountain folds.

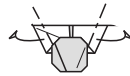

149. Round off with mountain folds.



150. Completed wheel. Repeat steps 144-149 behind.

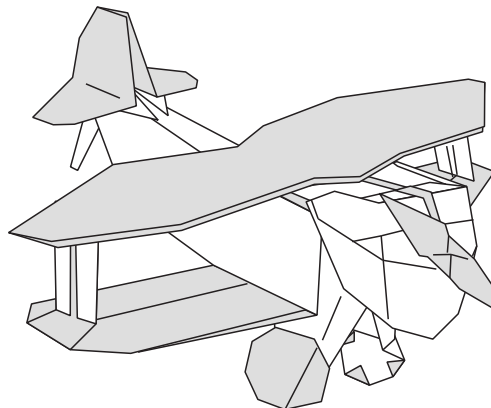

151. Completed Biplane II
©1996 Marc Kirschenbaum