

The Belle Damsel

By Perry Bailey on request by
Valerie Vann.

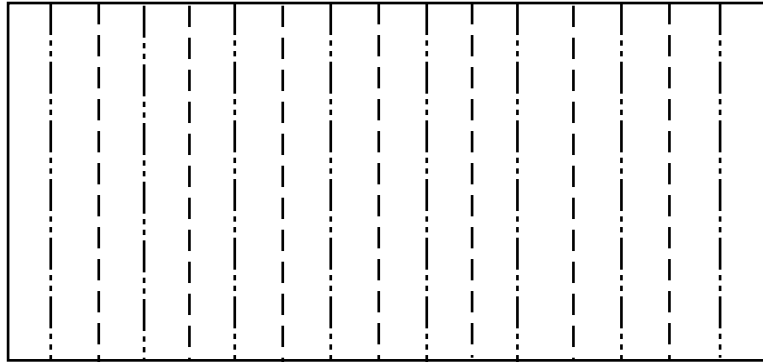

1. Use foil paper for best effect on this model, While you could use kami, it will be more difficult and not as nice looking. Start with 1/2 of a square or 2:1 ratio piece of paper, large paper is not needed as a 6X3 piece of foil works well. Fold the foil into sixteenths, with skin color desired on the out side.

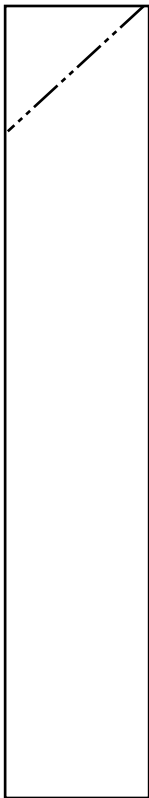

2. reverse fold in the first 2 corners on each side.

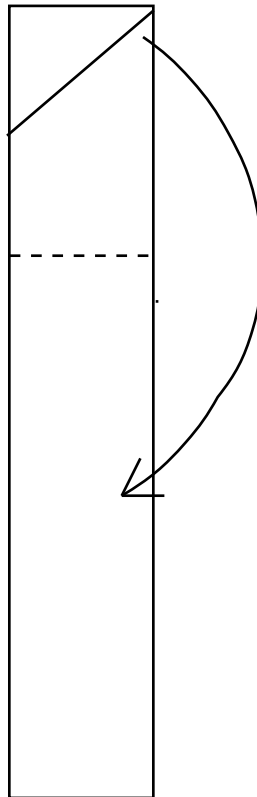

3. pull down the pleats to form the arms.

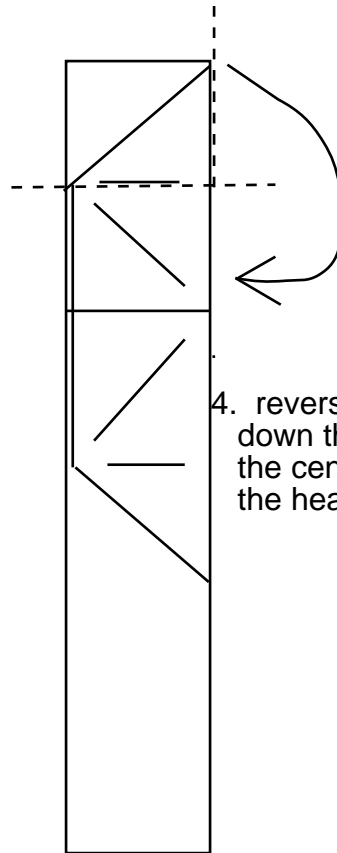

4. reverse fold down the top from the center fold to form the head.

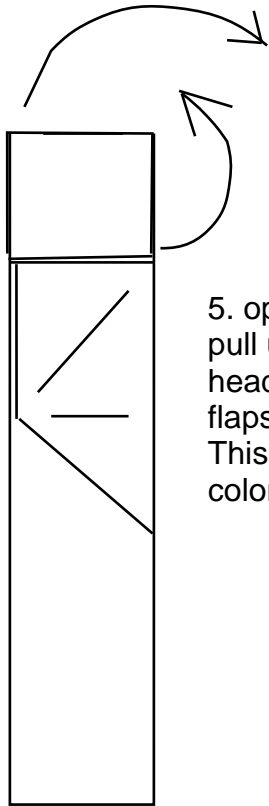

5. open up the figure and pull up the first layer of the head while flatening the inside flaps to effect a color change. This will give your model the same color hair as her gown.

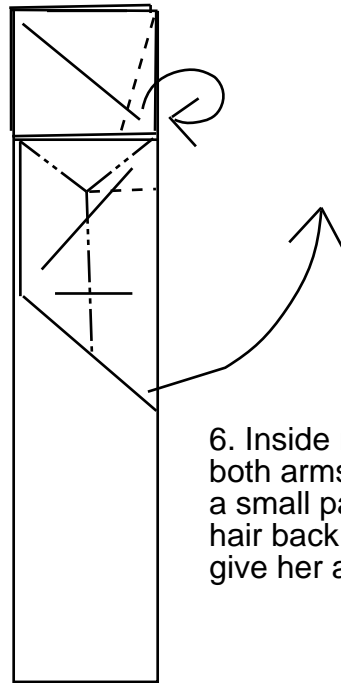

6. Inside rabbit fold both arms, then fold a small part of the hair back under to give her a face.

7. This is where all I know how to do is give a description. fan the model outwards at the bottom, while holding the top down to just below the arms. then use your thumb to inside of the model and wrap the pleats all the way around like a bell. the two ends of the foil will overlap. At that point make the dress as full or small as you like. To lock the bottom together just fold up a little of the bottom or hem of the dress upwards. and you are done.

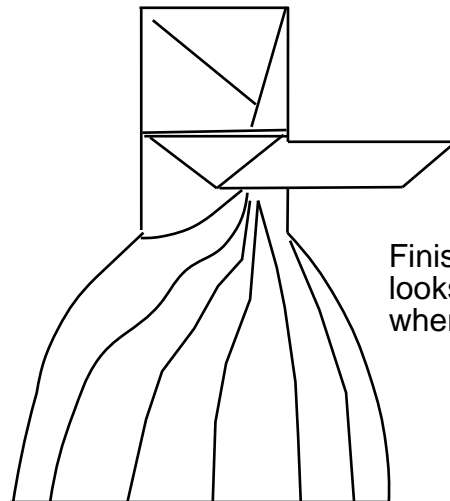
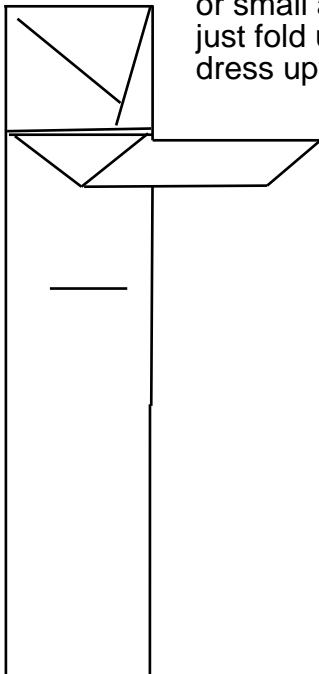

Finished looks best when small.